

# Installation Instructions and User Guide

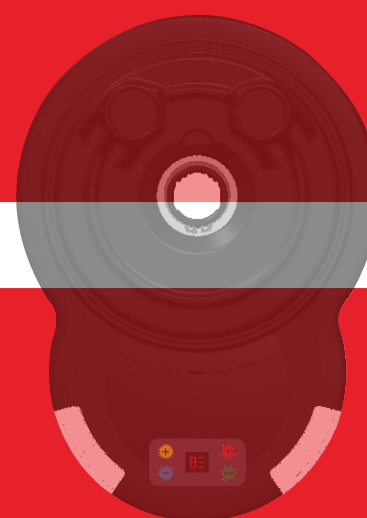

## Roller Door Opener

8001-0011-05 V2.0

### Important Safety Instructions

It is important for the safety of persons to follow all instructions. Follow all instructions as incorrect installation can lead to severe injury. Save these instructions.

- Before installing the drive, check that the door is in good mechanical condition, correctly balanced and opens and closes properly.
  - The drive is intended to be installed at least 2.5 m above the floor or other access level;
  - Can be used with doors having openings greater than 50 mm in diameter;
  - Is intended for automatic operation.
- The door is deemed to be well balanced and aligned if it:
- requires an equivalent amount of applied force to either manually open or close.
  - requires no more than 150N (15kg) of applied force to either manually open or close.
  - does not rise or fall more than 100mm when released at any point between fully open or fully closed positions.
  - does not rub on or incorrectly make contact with any supporting or surrounding structures
- Have a qualified person check and make repairs if required.
  - Before installing the drive, remove all unnecessary ropes or chains and disable any equipment, such as locks, not needed for powered operation.
  - Install the actuating member for the manual release at a height less than 1.8m
  - Permanently fix the label concerning the manual release adjacent to its actuating member.
  - Install any fixed control at a height of at least 1.5m and within sight of the door but away from moving parts.
  - Permanently fix the labels warning against entrapment in a prominent place or near any fixed controls.
  - After installation, ensure that the mechanism is properly adjusted and that the drive reverses when the door contacts a 50 mm high object placed on the floor, for drives incorporating an entrapment protection system depending on contact with the bottom edge of the door.
  - After installation, ensure that the parts of the door do not extend over public footpaths or roads.
  - After installation, ensure that the drive prevents or stops the opening movement when the door is loaded with a mass of 20 kg, fixed centrally on the bottom edge of the door (for drives that can be used with doors having openings larger than 50 mm in diameter).
  - Never use the Drive unless the garage door is in full view and free from any object which may impede its movement such as cars or persons.
  - This appliance can be used by children aged from 8 years and above and persons with reduced physical, sensory or mental capabilities or lack of experience and knowledge if they have been given supervision or instruction concerning use of the appliance in a safe way and understand

- the hazards involved.
- Children shall not play with the appliance.
- Cleaning and user maintenance shall not be made by children without supervision
- Do not allow children to play with door controls. Keep remote controls away from children;
- Watch the moving door and keep people away until the door is completely opened or closed.
- Take care when operating the manual release since an open door may fall rapidly due to weak or broken springs, or being out of balance.
- Frequently examine the installation, in particular check cables, springs and mountings for signs of wear, damage or imbalance. Do not use if repair or adjustment is needed since a fault in the installation or an incorrectly balanced door may cause injury.
- Each month check that the drive reverses when the door contacts a 50 mm high object placed on the floor. Adjust if necessary and recheck since an incorrect adjustment may present a hazard.
- Never attempt to open or close the garage door by pulling on the Engage/Disengage Cord.
- Removal of the protective covers must only be performed by a technically qualified person.
- Never attempt to make any repairs or remove covers from the Drive without first disconnecting the power cord from power supply.
- For safety reasons always ensure that the garage door is fully open and stationary before driving into or out of the garage.
- For security reasons always ensure the garage door is fully closed and stationary before moving out of its view.
- Keep hands and loose clothing clear of the Drive and moving garage door at all times.
- In order for the Safety Reverse system to function it must first encounter an obstruction in the form of an object/person on to which some force must be exerted. As a result the object/person/garage door may suffer damage and/or injury.
- Adjustments to the Safety Reverse system settings must only be carried out by a technically qualified person.
- The Safety Reverse System is designed to work on STATIONARY objects only. Serious personal injury, death and/or property damage may occur if the garage door comes into contact with a moving object during an opening or closing movement.
- For additional safety we strongly recommend the inclusion of Safety Beams. Although the Drive incorporates a pressure sensitive Safety Reverse system, the addition of Safety Beams will greatly enhance the safety of an automatic garage door and provide additional peace of mind. In some countries it is a mandate of law to fit Safety Beams. It is the sole responsibility of the owner/installer to fit Safety Beams in those countries that so require.

## A Installation and Setup

### Check Side Room Requirement

1

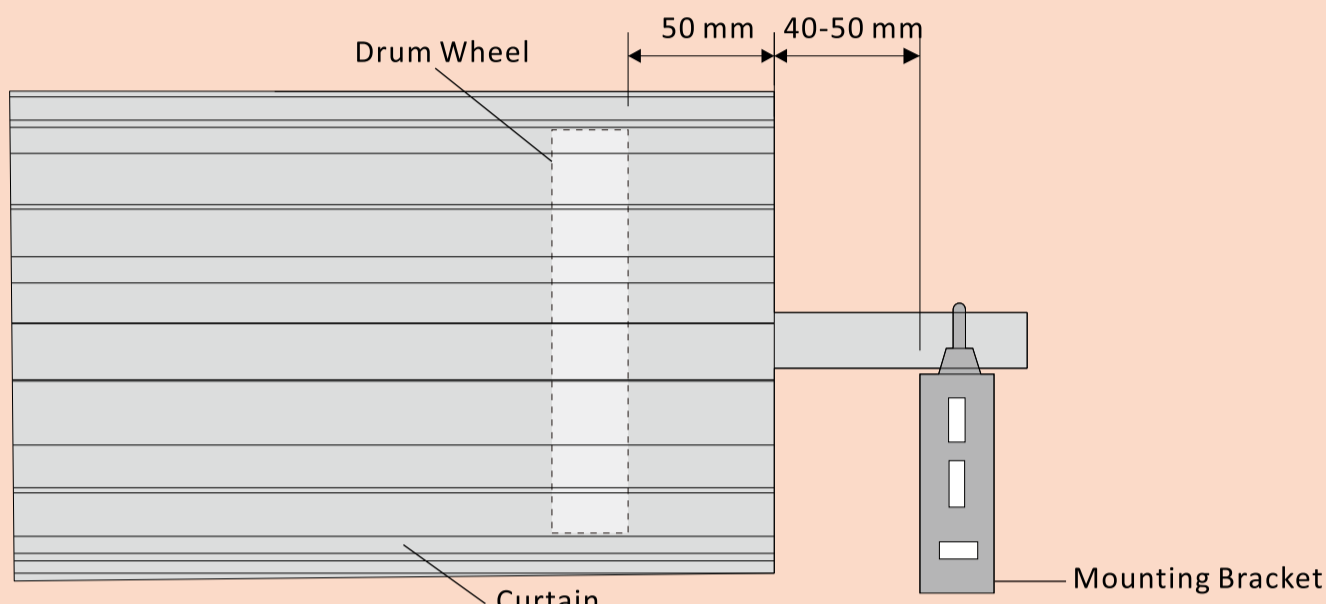

2

### Fit Opener to Door (right hand installation described)

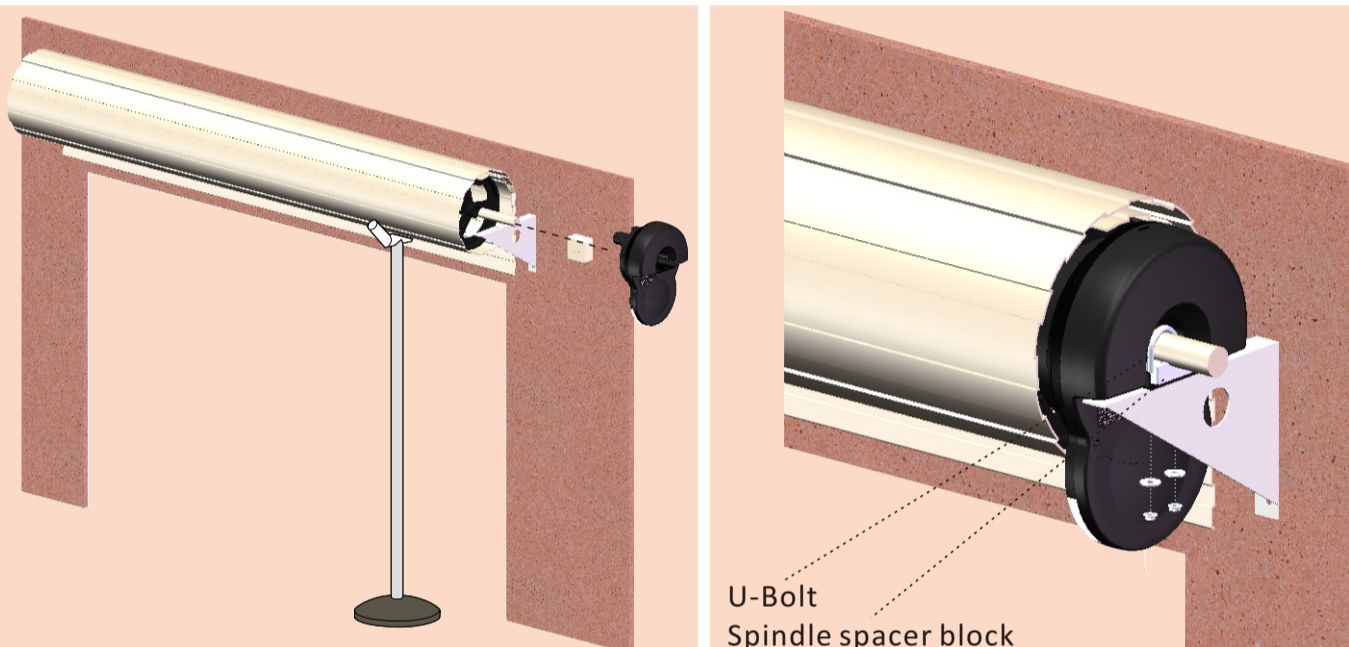

3

### Select Installation Side

- Determine to which end of the door the Opener will be installed and select the dip switch according to the following:
- Left Hand Side Installation - Dip (  NO )
  - Refer Sec II for dip switch location
  - Note - Installation side is referred to as "inside looking out"
- Right Hand Side Installation - Dip (  NO )

4

### Pin Curtain to Drum Wheel

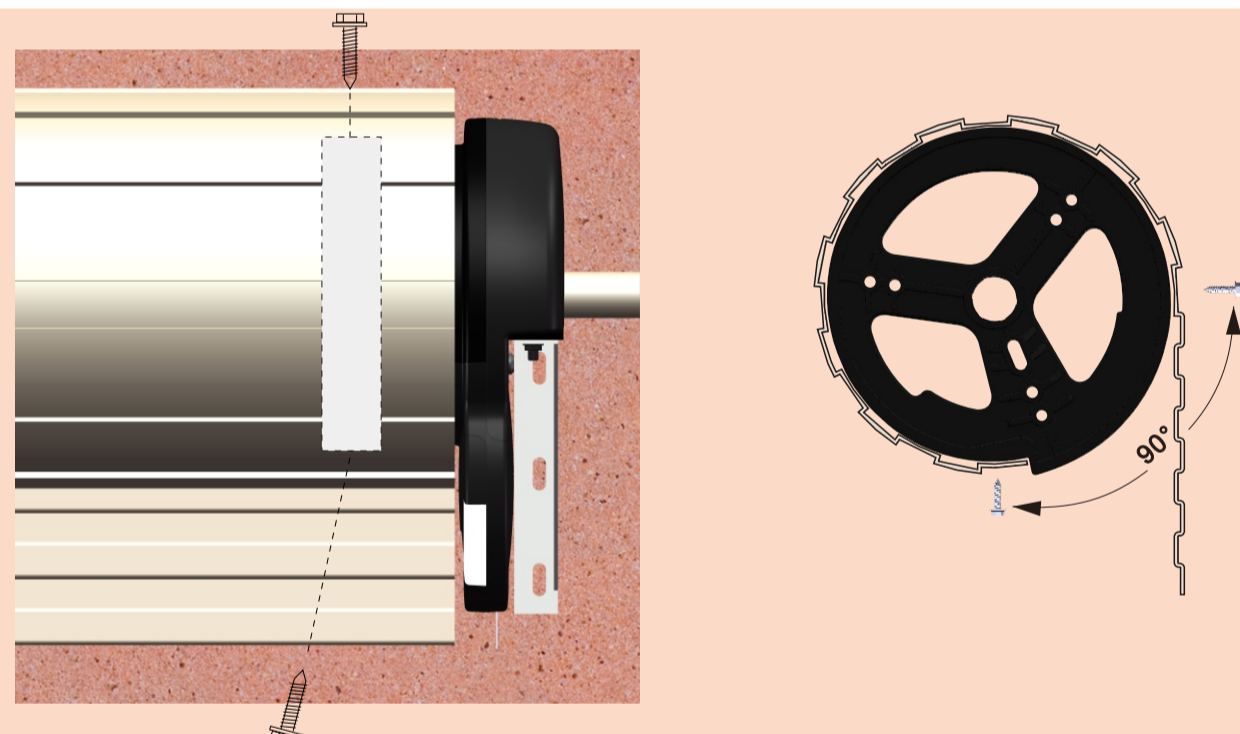

5

### Fit Weight Bar, Attach Entrapment Warning Label and Connect to Power Supply

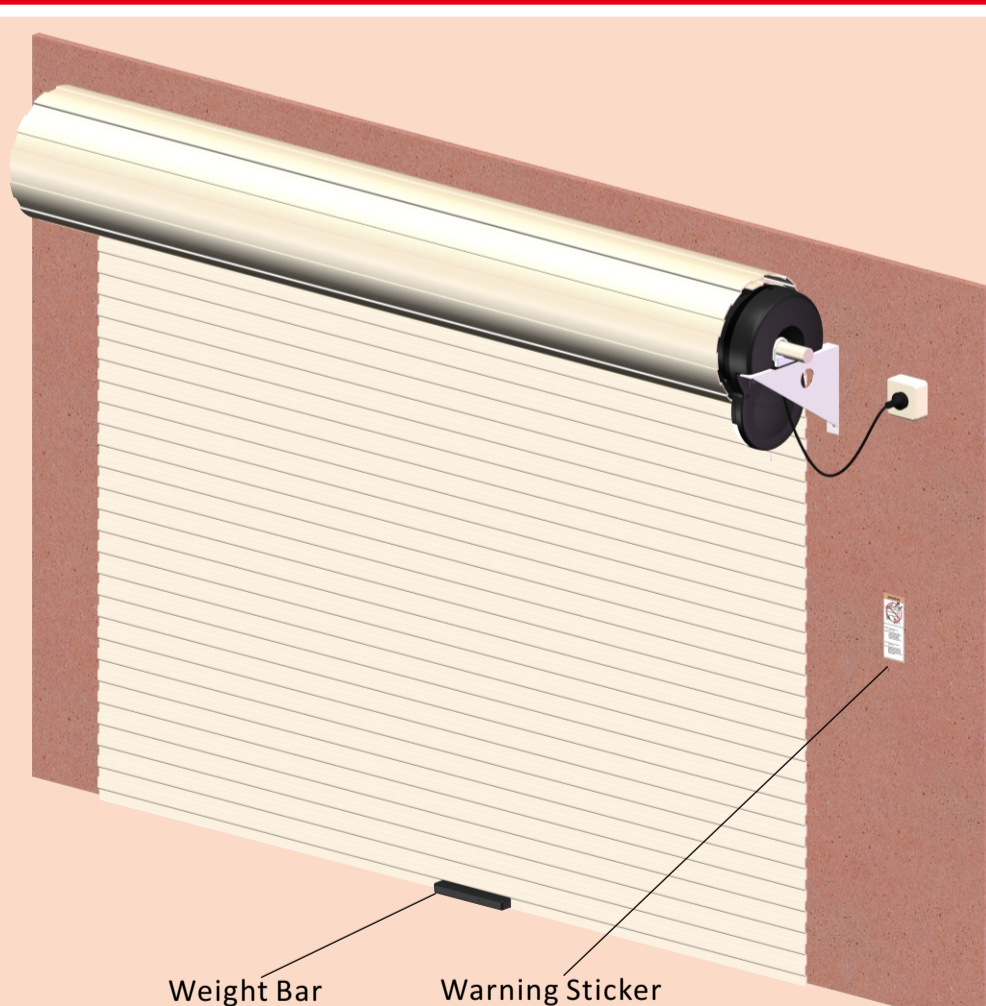

## B Learning

### 1 Close Limit

- 1.) Long press until is displayed
- 2.) Use and to move the door to close position
- 3.) Momentarily press to store closed position, is displayed

### 2 Open Limit

- 4.) Use and to move the door to open position
- 5.) Momentarily press to store open position, is displayed
- 6.) Momentarily press door will first open to find the track stop (rP) and then automatically close to learn safety reverse force values - display will extinguish - Learning completed.

Note: After every power outage the door will first open to find the reference point (rP). It will only be possible to close the door once it has found the reference point.

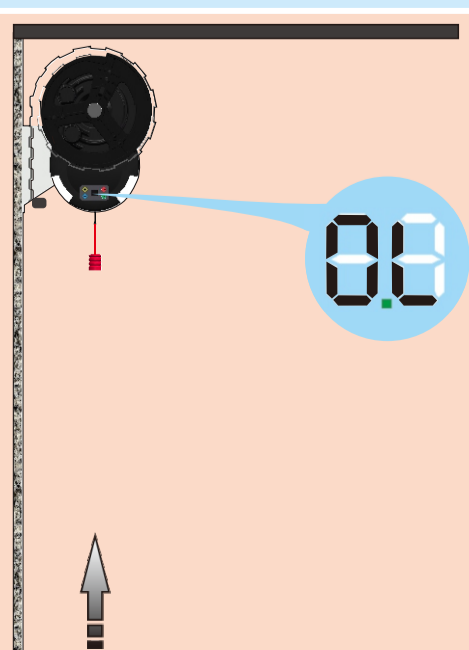
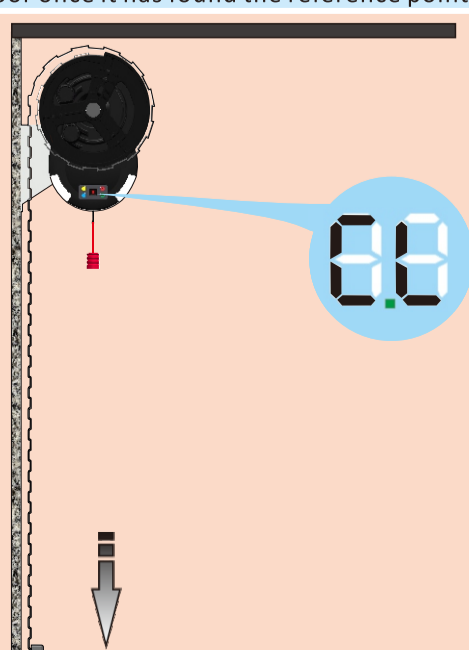

## C OPTIONAL: Fine Tune Safety Offset Value

Safety Offset Value determines how easily the door Safety Reverses/Safety Stops when hitting an obstruction. In order to prevent "ghosting" on a big, badly sprung or worn out door, Safety Value needs to be set to a **higher value** (max.= **F5**); In order to achieve a more sensitive Safety Reversing, Safety Offset Value needs to be set to a **lower value** (min.= **F1**). Safety Offset Values can be fine tuned **at any time**.

1 Fine Tune Safety Offset Value	2 Set Safety Offset Value to Maximum
1.) In Standby, Press <b>+</b> or <b>-</b> . The current Safety Offset Value is shown. 2.) Press <b>+</b> to increase or <b>-</b> to decrease the Value, <b>F1</b> being the most sensitive and <b>F5</b> being the least sensitive value. 3.) To confirm new Safety Offset Value press <b>✓</b> . 4.) To leave without changes wait 10 seconds or press <b>✗</b> .	1.) To achieve an installation with a <b>maximum of power and least sensitive</b> Safety Reverse/Safety Stop set Safety Offset Value to <b>F5</b> as shown besides.  <b>ATTENTION</b> , with Safety Offset Values set to Maximum the door is dangerous and it is recommended to use a Photo Safety Beam.

## D Control Panel Functions

**In Learn Mode CL and DL:** Moves door in backwards or forwards direction  
**In Standby:** Increase or Decrease Force Offset Values Press **+** and **-** together: Enter Function Setup Menu  
**In Function Setup Menu:** Scroll Functions and Values  
**In Transmitter Setup Menu:** Scroll Functions

**Short Press:** Enter Transmitter Setup Menu (see **F 3**)  
**Long Press (5 sec):** Forced Release (see **G CL DL FL**)

**In Standby:** Acts as Run Button (Open and Close Door)  
**In Setup Menu:** Confirm Button and Courtesy Light both act as run buttons (Open, Stop, Close the door)

## E Transmitter Functions Ex Factory

1 Run Function
Alternately Opens, Closes or Stops the Garage Door.
2 Light / Transmitter Coding
Short Press - Switches Courtesy LED Light ON and OFF. Long Press (5 sec) - Enter Transmitter Setup Menu. see <b>F 3</b> for details.
3 Vacant
4 Vacant

### Battery Replacement

## F Transmitter Coding

1 Bulk Coding via Transmitter (setup as shown in E)	3 Assign Certain Functions to Certain Transmitter Buttons														
<ul style="list-style-type: none"> <li>- Long press <b>Light Function</b> (Button 2 on pre-coded Transmitter) for 5 sec, — Courtesy LED Light begins to flash.</li> <li>- Press new Transmitter <b>twice</b>, — Learning Complete.</li> </ul>	<ul style="list-style-type: none"> <li>- Short press <b>✓</b> on Opener, → Use <b>+</b> and <b>-</b> to choose the desired function (see below).</li> <li>- Short press Transmitter Button <b>twice</b>, → Learning Complete.</li> </ul>														
2 Delete all Transmitters															
<ul style="list-style-type: none"> <li>- Short press <b>✓</b> on Opener,</li> <li>- → Long press 5 sec <b>✓</b> until light starts flashing,</li> <li>- → Deleting Complete.</li> </ul>	<table border="1"> <tr> <td><b>bu</b> Bulk Coding (TX learns Functions as shown in <b>E</b>)</td> <td></td> </tr> <tr> <td><b>ho</b> Ventilation / Holiday Mode Function Puts Opener into dormant state if closed.</td> <td></td> </tr> <tr> <td><b>ru</b> Run Function Open/Stop/Close</td> <td></td> </tr> <tr> <td><b>li</b> Light Function Controls Courtesy LED Light</td> <td></td> </tr> <tr> <td><b>ro</b> Run Function/Auto Close Override Open/Stop/Close, without Auto-Close</td> <td></td> </tr> <tr> <td><b>oo</b> OPEN Function Only OPENS Door</td> <td></td> </tr> <tr> <td><b>co</b> CLOSE Function only CLOSES Door</td> <td></td> </tr> </table>	<b>bu</b> Bulk Coding (TX learns Functions as shown in <b>E</b> )		<b>ho</b> Ventilation / Holiday Mode Function Puts Opener into dormant state if closed.		<b>ru</b> Run Function Open/Stop/Close		<b>li</b> Light Function Controls Courtesy LED Light		<b>ro</b> Run Function/Auto Close Override Open/Stop/Close, without Auto-Close		<b>oo</b> OPEN Function Only OPENS Door		<b>co</b> CLOSE Function only CLOSES Door	
<b>bu</b> Bulk Coding (TX learns Functions as shown in <b>E</b> )															
<b>ho</b> Ventilation / Holiday Mode Function Puts Opener into dormant state if closed.															
<b>ru</b> Run Function Open/Stop/Close															
<b>li</b> Light Function Controls Courtesy LED Light															
<b>ro</b> Run Function/Auto Close Override Open/Stop/Close, without Auto-Close															
<b>oo</b> OPEN Function Only OPENS Door															
<b>co</b> CLOSE Function only CLOSES Door															

## G Menu Functions

1.) To Enter Function Setup Menu: press **+** and **-** at the same time.  
 2.) Use **+** and **-** to scroll up or down through the functions.  
 3.) Press **✓** to select the desired function.  
 4.) Now choose value with **+** and **-**. Confirm chosen value by pressing **✓**.  
 5.) To Exit Function Setup Menu at any time: press **✗**.

Function	Description	Values
<b>Sb</b>	Safety Photo Beam	<b>0F</b> Disable Safety Beam <b>0A</b> Enable Safety Beam in CLOSE Direction
<b>Ac</b>	Automatic Close Function <i>Note: Safety Beams <b>Sb</b> must be installed and enabled</i>	<b>0F</b> Safety Beam Function <b>Sb</b> not enabled <b>05</b> 5 sec / 30 sec <b>15</b> 15 sec / 90 sec <b>30</b> 30 sec / 180 sec <b>0F</b> No Auto-Close If Safety Beam is activated by passing car or person: Door automatically closes after 5/15/30 sec. If Safety Beam is <b>NOT</b> activated by passing car or person: Door automatically closes after 30/90/180 sec.
<b>Sp</b>	Running Speed of Opener	<b>Hh</b> High Speed <b>Ll</b> Low Speed After setup, <b>CL</b> will start. Follow Steps <b>B 1-2</b>
<b>Ss</b>	Slow Stop Function	<b>Sh</b> Short Slow Stop <b>Ll</b> Long Slow Stop After setup, <b>CL</b> will start. Follow Steps <b>B 1-2</b>
<b>Ll</b>	Courtesy Light illumination time	<b>0F</b> 1 min <b>02</b> 2 min <b>03</b> 3 min
<b>Pf</b>	Partial reverse / Full reverse	<b>0F</b> After Hitting Obstruction, Door will: <b>Fully Reverse</b> <b>0A</b> After Hitting Obstruction, Door will: <b>Partial Reverse</b>
<b>Sr</b>	Signal Reverse / Signal stop	<b>0F</b> At press TX in Close Direction, Door will: <b>Stop</b> <b>0A</b> At press TX in Close Direction, Door will: <b>Reverse</b> Handsendersignal während ZU-Fahrt: Antrieb <b>reversiert</b>
<b>ds</b>	Door Service Monitor	<b>0F</b> OFF <b>0A</b> If Door is out of Balance, <b>Light will flash</b> during run to warn user
<b>rt</b>	Maximum Run Time	<b>30</b> Opener Stops after 30 sec Run Time <b>60</b> Opener Stops after 60 sec Run Time
<b>Ho</b>	<b>Holiday Mode:</b> Turn on by pressing Holiday Function (Button 2 on Pre-Coded TX) for 3 seconds. Places Opener in a dormant state after if closed. <b>Hh</b> is displayed.	
<b>Ff</b>	<b>Factory Reset:</b> Initiate Reset by pressing <b>✗</b> and power on at same time until Display shows <b>Ff</b> . Previously coded TX will not be deleted.	
<b>CL</b>	Drive Door into CLOSE Position by <b>+</b> and <b>-</b> . Long Press <b>✓</b> for 5 sec until Display shows <b>CL</b> .	
<b>DL</b>	Drive Door into OPEN Position by <b>+</b> and <b>-</b> . (Part of Learning procedure)	
<b>FL</b>	Part of Learning procedure /After Power ON	

## H Error codes

If an error is encountered the Courtesy Light will triple flash and an error code (Show **Ff** in box) will illuminate on the display panel

<b>E1</b>	<b>Error:</b> Safety Beams misaligned or damaged. <b>Fix:</b> Check Safety Beam pilot light to ensure that beams are aligned. Check that wiring is intact and properly connected.
<b>E2</b>	Not applicable
<b>E3</b>	<b>Error:</b> Door Service Monitor - indicates that door is out of balance. <b>Fix:</b> Disengage opener from door and manually check if door is correctly balanced.
<b>E4</b>	<b>Error:</b> Run Time - Indicates that 30 sec Run Time limit has been reached. <b>Fix:</b> Refer to Menu Functions section and increase Run Time to 60 sec.
<b>E5</b>	<b>Error:</b> Exceed factory set maximum power level during Limit Learn Mode (LL). <b>Fix:</b> Check spring balance of door. May suggest the door is too heavy for the opener.
<b>E6</b>	<b>Error:</b> Exceed offset level during safety reverse or safety stop. <b>Fix:</b> No action required.
<b>E7</b>	<b>Error:</b> Exceed maximum current limit. <b>Fix:</b> No action required.
<b>E8</b>	<b>Error:</b> Blown fuse <b>Fix:</b> Change the fuse
<b>E9</b>	<b>Error:</b> Hall sensor signal not present. <b>Fix:</b> Check that hall sensor connector is firmly plugged into main PCB. Replace hall sensor assembly.

## I Connection Plan and Installation Side Selection

**Coax Antenna**

**COM ANT**

**SB** (Safety Beam)

**COM** (Common)

**+24V** (Power)

**NO** (Normally Open)

**Installation Side Selection:** Left Side or Right Side

**Open/Stop/Close** button wiring

**Safety Photo Beam** wiring